

SEALED MAGNETIC CATCH

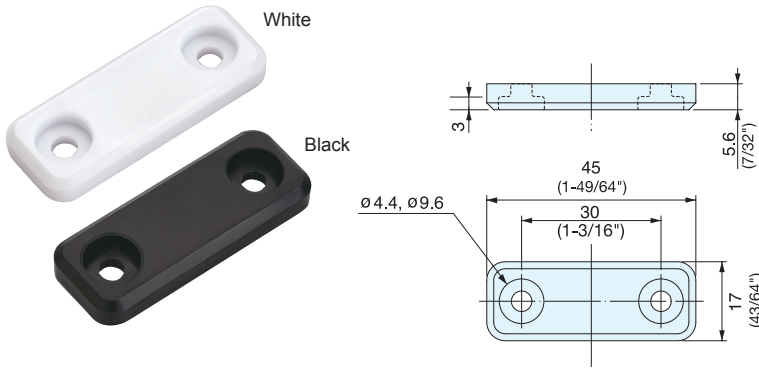

MC-JM45



- Hermetically sealed, ideal for high corrosion environments.
- No metal-to-metal contact, ideal for cleanroom applications.
- Strong magnetic force.
- Optional counterplate sold separately:
 - Stainless Steel - MC-JM49, AS-68
 - Plastic Sealed - MC-JMP45WT, MC-JMP45BL

Item No.	Magnetic Force (kg)	Weight (g)	Box (pcs)	Carton (pcs)
MC-JM45WT	3 (6.6 lbs)	8.5	100	1000
MC-JM45BL				

Part Name	Material	Finish/Color
Body	Polypropylene	White (WT)/Black (BL)
Magnet	Neodymium	-

SEALED MAGNETIC CATCH



MC-JM50

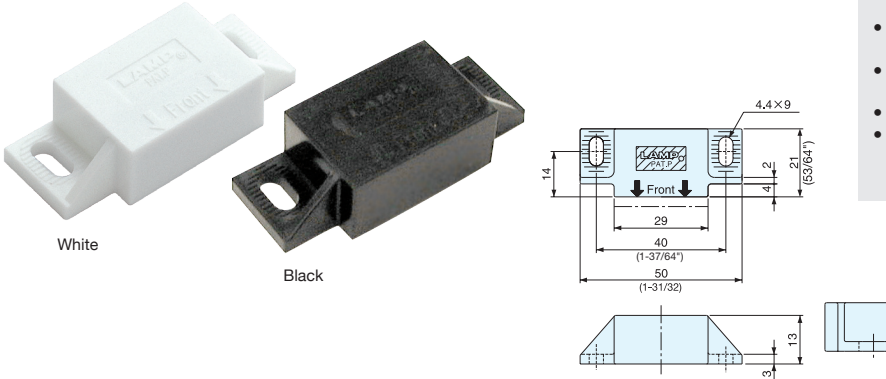

- Hermetically sealed, ideal for high corrosion environments.
- No metal-to-metal contact, ideal for cleanroom applications.
- Strong magnetic force.
- Optional counterplate sold separately:
 - Stainless Steel - MC-JM49, AS-68
 - Plastic Sealed - MC-JMP45

Item No.	Magnetic Force (kg)	Weight (g)	Box (pcs)	Carton (pcs)
ML-JM50WT	3 (6.6 lbs)	21	24	480
MC-JM50BL				

Part Name	Material	Finish/Color
Body	Polyacetal	White (WT)/Black (BL)
Magnet	Neodymium	-

SEALED MAGNETIC CATCH



MC-JM63G

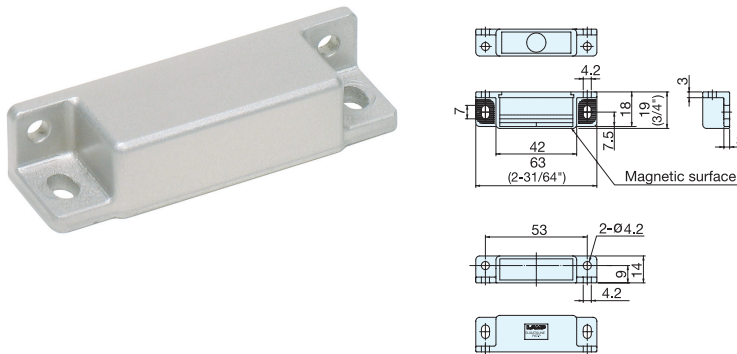

- Hermetically sealed, ideal for high corrosion resistance.
- No metal-to-metal contact, ideal for cleanroom application.
- Strong magnetic force.
- Optional counterplate:
 - Stainless Steel - MC-JM49, AS-68
 - Plastic Sealed - MC-JMP45

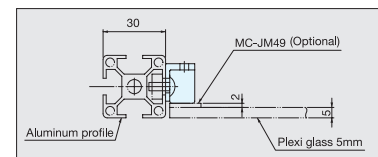

Item No.	Magnetic Force (kg)	Weight (g)	Box (pcs)	Carton (pcs)
MC-JM63G-15	1.5 (3.3 lbs)	20	50	500
MC-JM63G-30	3.0 (6.6 lbs)			
MC-JM63G-50	5.0 (11.0 lbs)			

Part Name	Material	Finish/Color
Body	Polyacetal	Light Grey
Magnet	Neodymium	-