







Beschlag zum Drehen und seitlich Einschieben von Holztüren bis 30 kg. Ermöglicht multifunktionelle Raumgestaltung, gepart mit flächenbündigem Design.

Produkt-Highlights

-  **Flexibilität** Ausgesprochen flexible Türmasse für hohen Gestaltungsfreiraum
-  **Komfort** Leichte, ruhige Bedienung durch Dämpfeinzug und Scharnieren mit integrierter Schliessdämpfung

Technische Vorgaben

-  15–30 kg
-  1851–2300 mm
-  300–900 mm
-  19–50 mm







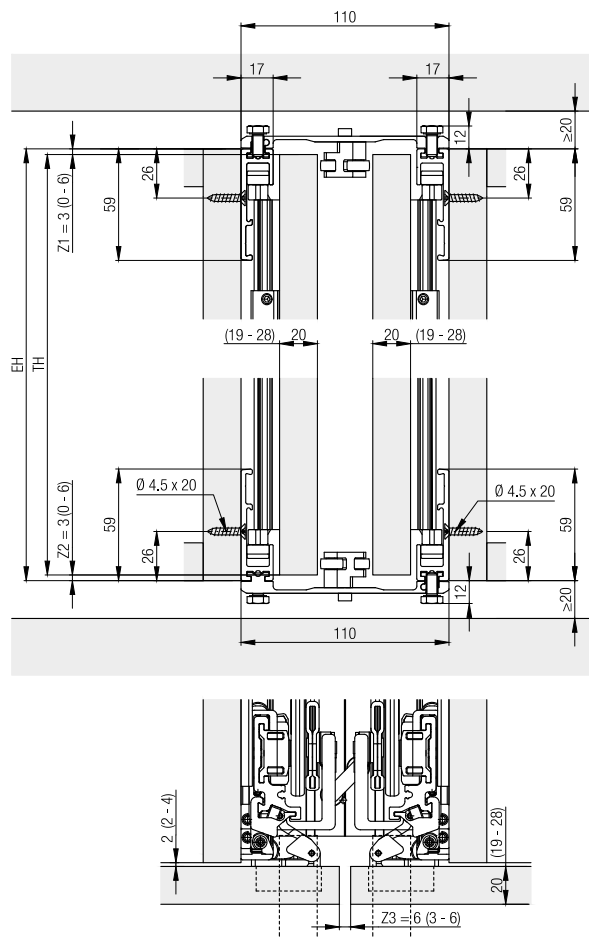
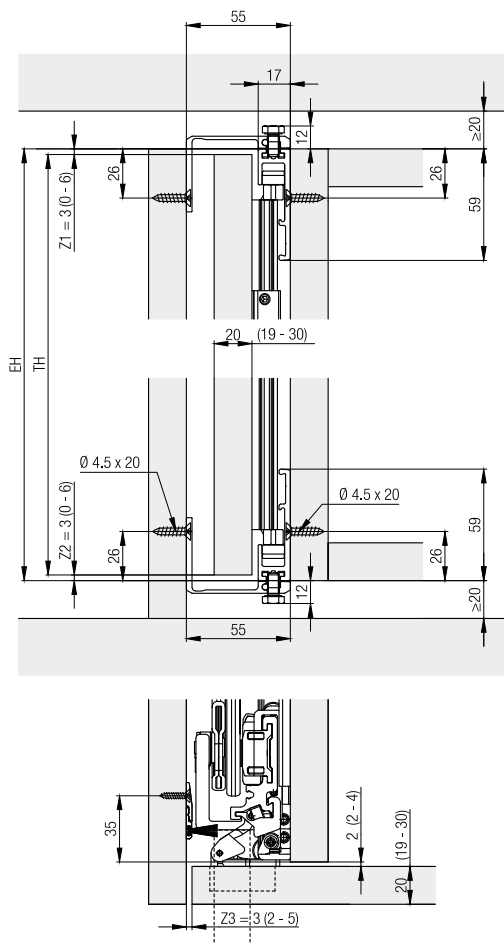



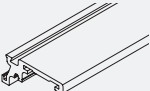

Einbaubeispiele

Türe auf Boden und Deckel aufschlagend



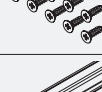
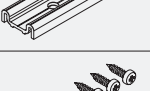

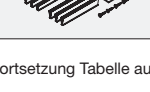
Garnitur für 1 Dreh-Einschiebetüre bis 30 kg

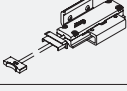
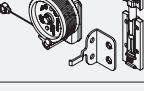
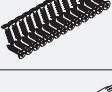

		Nr.			
Hawa Concepta 30, für 1 Türe		27649			
		27649	Nr.		
Garnitur bestehend aus:					
	Holm, 2300 mm, Aluminium, eloxiert			1	24699
	Holmführung, spielfrei, mit Kunststoffrollen			2	25656
	Torsionsplatte			1	27704
	Schere komplett, Stahl verzinkt			1	22593
	Scherenführung vorne, Aluminium, eloxiert			1	25592
	Scherenführung hinten, Aluminium, eloxiert			1	25596
	Scherenlager hinten, 55 mm, Stahl, verzinkt			1	25855
	Topfscharnier, mit Dämpfung, Stahl, vernickelt, Set à 3 Stück			1	27654
	Schrauben-Set für Topfscharniere, 4x16 mm, Set à 10 Stück			1	25935
	Distanzprofil, 860 mm, gelocht, Kunststoff, schwarz			1	22861
	Schrauben-Set zu Distanzprofil, PH 4x16 mm, Set à 7 Stück			1	25562
	Bürstenführung, Kunststoff, schwarz, Set à 3 Stück	1	25815		

Fortsetzung Tabelle auf nächster Spalte

Fortsetzung Tabelle von vorheriger Spalte

	Anschlagabdeckkappe Hawa Concepta, tiefenverstellbar, oben links/unten rechts	1	27657
	Anschlagabdeckkappe Hawa Concepta, tiefenverstellbar, oben rechts/unten links	1	27658
	Abdeckkappen, Edelstahl, 1 Paar	1	24739
	Führungsschiene, 896 mm, Aluminium, eloxiert, gelocht	2	24535
	Anschlagdämpfer, mit Haltebügel	1	24660
	Türeinzug 30/40, mit Endlagendämpfung, Kunststoff, schwarz	1	25813
	Endlagendämpfung, mit Abdeckkappen, Kunststoff, schwarz	1	25862
	Schrauben-Set, 4,5x20 mm, Set à 22 Stück	1	22451
	Inbusschlüssel, mit Griff, 3 mm	1	13164
	Montagehilfe, Kunststoff, rot	1	25816

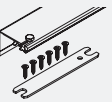
Korpus Verbindungsprofile

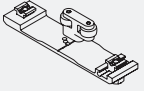
		mm	Nr.
	Connector 55 mm, für eine Dreh-Einschiebetüre, Aluminium, eloxiert, 2 Stück	650	25438
	Connector 55 mm, für eine Dreh-Einschiebetüre, Aluminium, eloxiert, 1 Stück	650	23221
		900	23222
	Connector 110 mm, für zwei Dreh-Einschiebetüren, Aluminium, eloxiert, 1 Stück	650	23223
		900	23224
	Connector 110 mm, für zwei Dreh-Einschiebetüren, Aluminium, eloxiert, 1 Stück (für Montage vor fixem Sockel)	26	23225

Führungen

		Nr.
	Führung für zwei einliegende Dreh-Einschiebetüren, Aluminium	25680

Türgriffe

		mm	Nr.
	Türgriff, Aluminium, eloxiert	400	22692

Türgriffhöhe

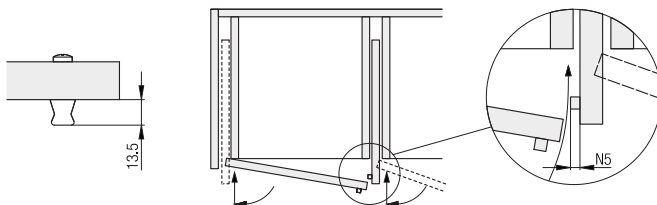

Weitere Einbaubeispiele
Türe einliegend

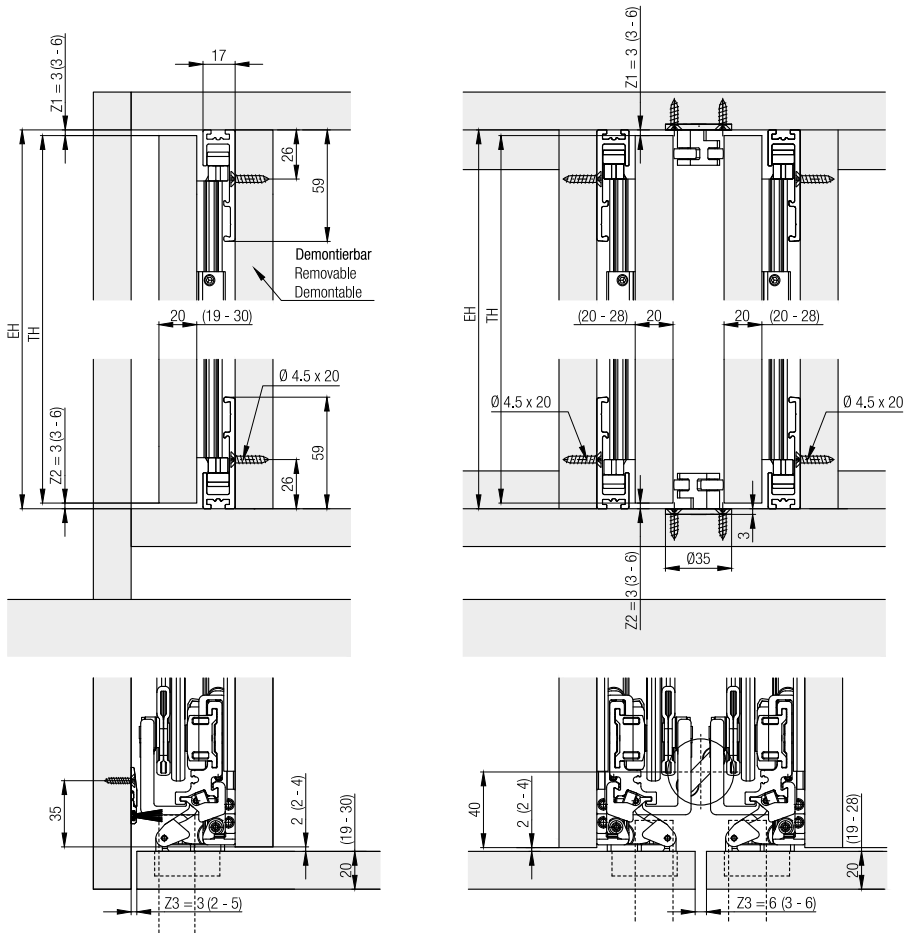

Türe in Mauernische

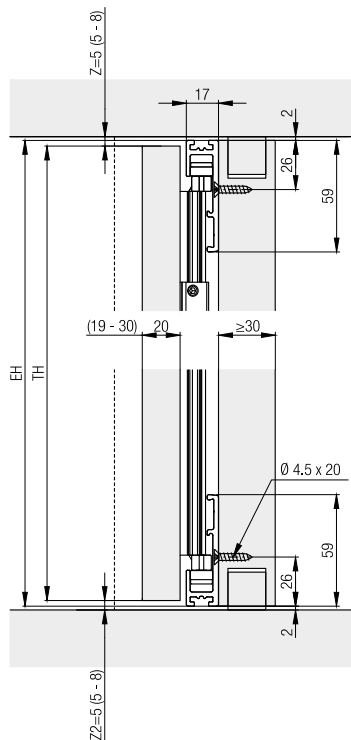

Türdicke 31-50 mm

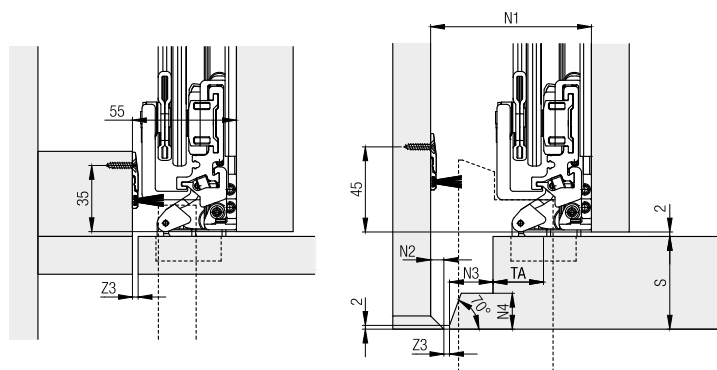

S	N1	N2	N3	N4
19-30 mm	55 mm	0 mm	0 mm	0 mm
33 mm	58 mm	0 mm	3 mm	3 mm
36 mm	63 mm	2 mm	6 mm	5 mm
39 mm	67 mm	3 mm	9 mm	8 mm
42 mm	70 mm	3 mm	12 mm	11 mm
45 mm	75 mm	5 mm	15 mm	14 mm
48 mm	79 mm	6 mm	18 mm	17 mm
50 mm	83 mm	7 mm	21 mm	19 mm

Berechnung Beschlagstiefe

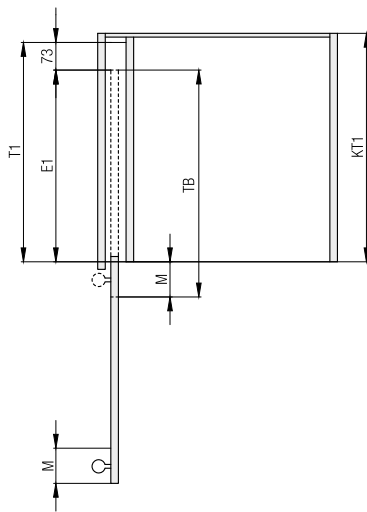

$$T1 = TB - M + 73 \text{ mm}$$

$$E1 = T1 - 73 \text{ mm}$$

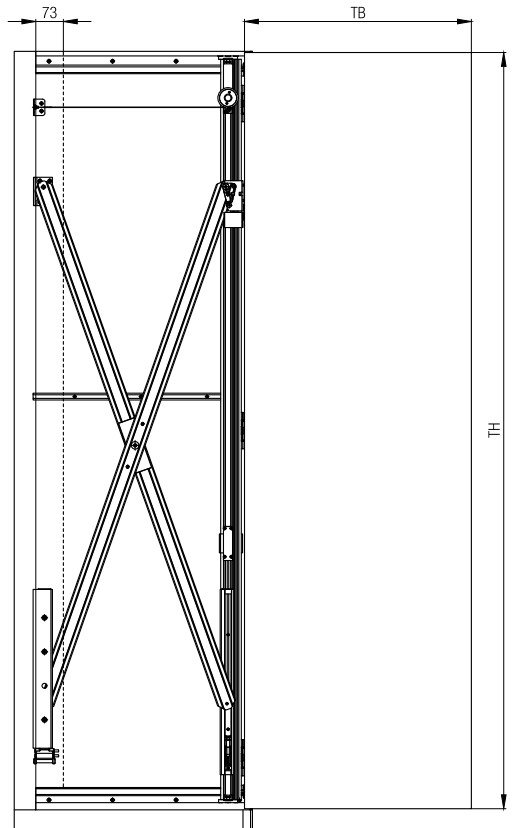

	T1	TH	E1
Hawa Concepta 30	≤ 900 mm	1851 - 2300 mm	300 - 827 mm

Berechnungen Gewicht- und Türgrößenverhältnis

Das Maximale Gewicht muss je nach Türgrößenverhältnis angepasst werden.

TH \ TB	300	350	400	450	500	550	600	650	700	750	800	850	900
2300	30	30	30	30	30	30	30	30	30	30	29	27	26
2250	30	30	30	30	30	30	30	30	30	30	28	27	25
2200	30	30	30	30	30	30	30	30	30	29	27	26	24
2150	30	30	30	30	30	30	30	30	30	29	27	25	24
2100	30	30	30	30	30	30	30	30	30	28	26	25	23
2050	30	30	30	30	30	30	30	30	29	27	25	24	23
2000	30	30	30	30	30	30	30	30	29	26	25	23	22
1950	30	30	30	30	30	30	30	29	27	26	24	23	21
1900	30	30	30	30	30	30	30	29	27	25	23	22	21
1851	30	30	30	30	30	30	30	28	26	24	23	21	20

Türgewicht in kg | TB = Türbreite in mm | TH = Türhöhe in mm

Zubehör

– Ausrichtbeschlag ab Seite 228

Planung/Ausführung

Konfigurieren Sie mit nur wenigen Klicks auf www.concepta.hawa.com

Weitere Informationen zum Produkt finden Sie auf www.hawa.com.