

System: Laufschiene eingenetet oder aufgeschraubt, keine Nut im Boden, ohne Blende, Clip-Laufwerk mit Finger-Justierrad, für 2 Holztüren bis 16 kg. Design Inslide/Mixslide

System: Running track groove or surface mounted, no groove in the floor, without panel, clip-on running gear with thumb wheel adjuster, for 2 wooden doors up to 16 kg. Design Inslide/Mixslide

Système: rail de roulement rainuré ou vissé en applique, aucune rainure dans le sol, sans chache, chariot de roulement à clipser avec molette de réglage, pour 2 portes en bois jusqu'à 16 kg. Design Inslide/Mixslide

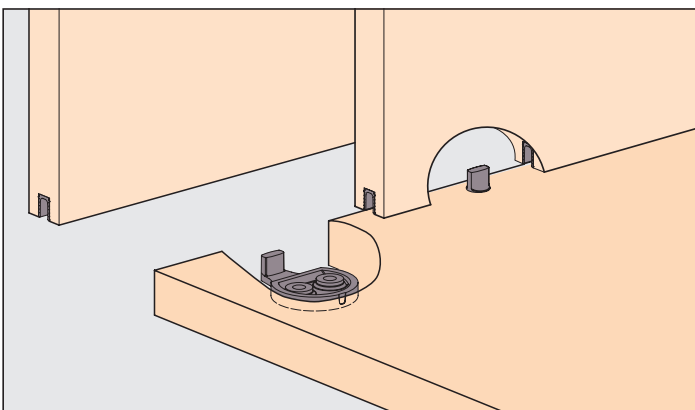

Bei zurückversetzter Seitenwand Stopper/Türmitnehmer unten setzen
 With set back side panel, place stopper/door follower at the bottom
 Placer la butée/entraîneur en bas si la paroi latérale de porte est décalée par rapport à la porte

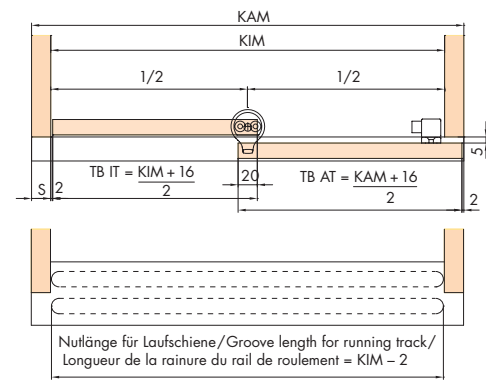

Einbaubeispiele/Mounting examples/Exemples de montage

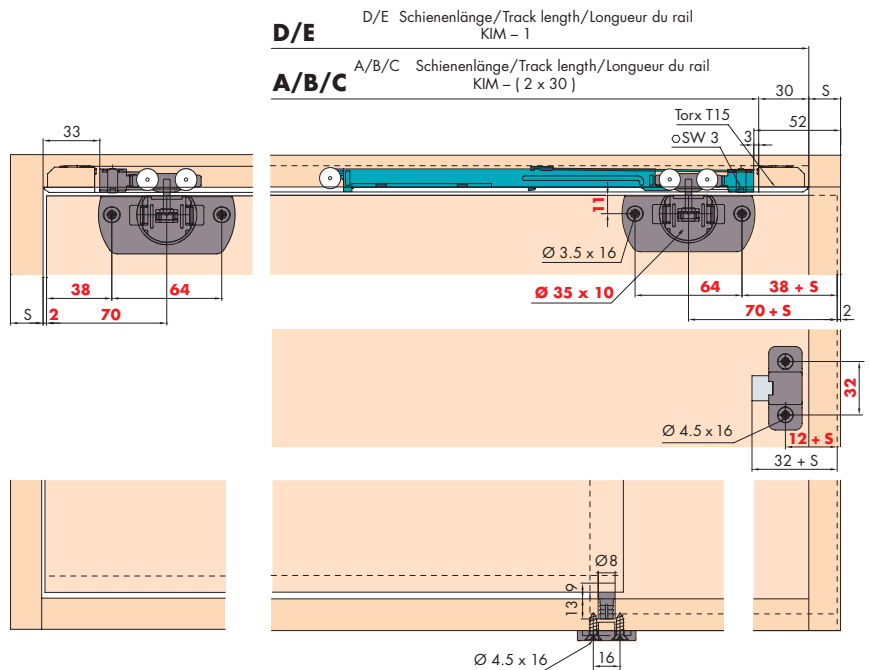
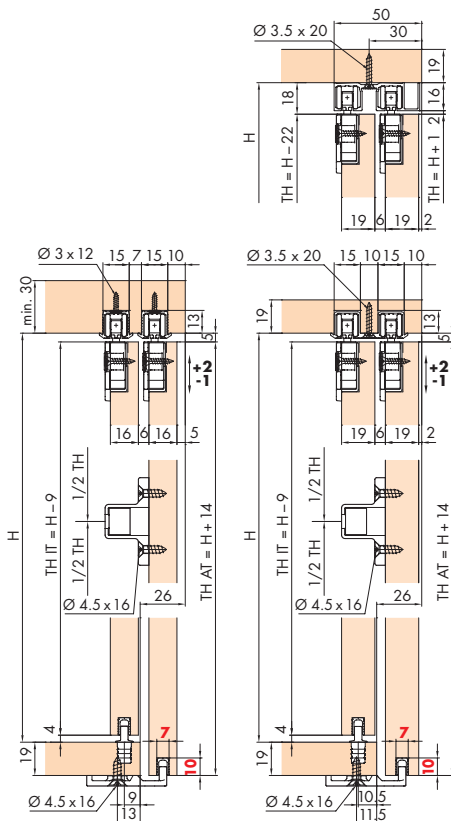

Türbearbeitung = rote Zahlen/Dimensions and drillings for doors = red numbers/Usinage de la porte = chiffres rouges

Dämpfung optional/Soft close optional/Amortissement en option 60/61

Befestigungsvarianten/Mounting options/Variantes de fixation

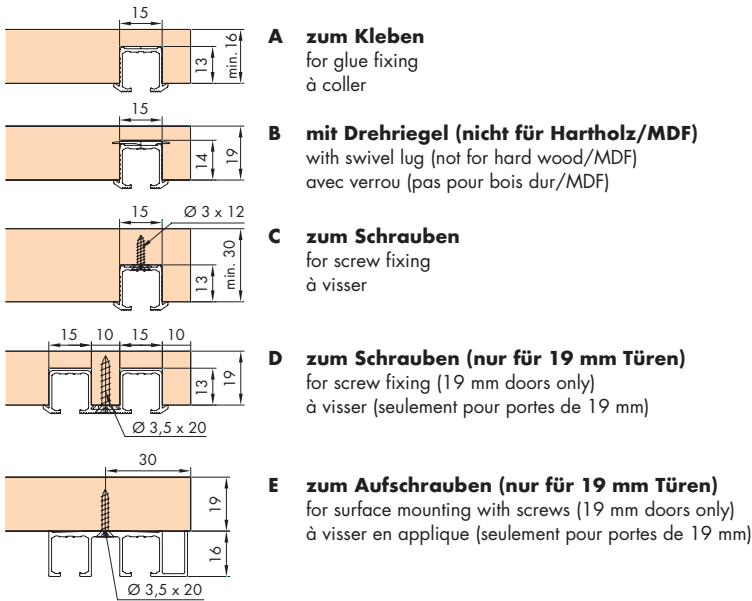

- A zum Kleben**
for glue fixing
à coller
- B mit Drehriegel (nicht für Hartholz/MDF)**
with swivel lug (not for hard wood/MDF)
avec verrou (pas pour bois dur/MDF)
- C zum Schrauben**
for screw fixing
à visser
- D zum Schrauben (nur für 19 mm Türen)**
for screw fixing (19 mm doors only)
à visser (seulement pour portes de 19 mm)
- E zum Aufschrauben (nur für 19 mm Türen)**
for surface mounting with screws (19 mm doors only)
à visser en applique (seulement pour portes de 19 mm)



Türgewichte
Door weights
Poids de portes **69**

Garnituren / Sets / Garnitures

2 Türen Doors Portes		No. 053.3304.071	
	4x		2x
	4x		1x
	1x		1x

Zubehör / Accessories / Accessoires

A Einfachlaufschiene Alu, zum Kleben
Single running track aluminium, for glue fixing
Rail de roulement simple en alu, à coller

Gr./Size	Art. No.
2500 mm	053.3229.250
3500 mm	053.3229.350
6000 mm	053.3229.600

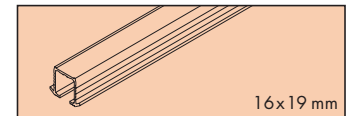

B Einfachlaufschiene Alu, mit Drehriegel (nicht für Hartholz/MDF)
Single running track aluminium, with swivel lug (not for hard wood/MDF)
Rail de roulement simple en alu, avec verrou (pas pour bois dur/MDF)

2500 mm	053.3227.250
3500 mm	053.3227.350
6000 mm	053.3227.600

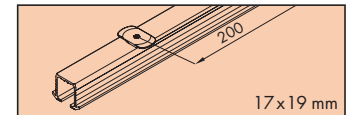

C Einfachlaufschiene Alu, zum Schrauben
Single running track aluminium, for screw fixing
Rail de roulement simple en alu, à visser

2500 mm	053.3225.250
3500 mm	053.3225.350
6000 mm	053.3225.600

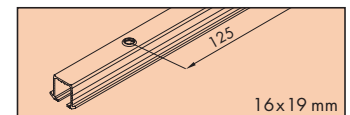

Schienenendstück, Kunststoff grau, mit Drehriegel
Track-end piece, plastic grey, with swivel lug
Pièce d'extrémité, plastique gris, avec verrou
(nicht für Hartholz/MDF, not for hard wood/MDF, pas pour bois dur/MDF)

2x	053.3211.081
----	--------------

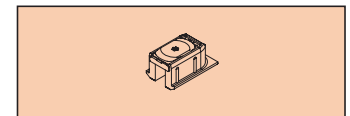

Schienenendstück, Kunststoff grau, zum Schrauben
Track end piece, plastic grey, for screw fixing
Pièce d'extrémité, plastique gris, à visser

2x	053.3210.081
----	--------------

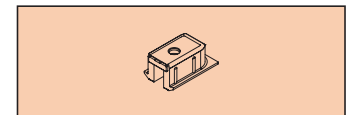

D Doppellaufschiene Alu, gelocht, zum Schrauben
Double running track aluminium, pre-drilled, for screw fixing
Rail de roulement double en alu, perforé, à visser

2500 mm	053.3226.250
3500 mm	053.3226.350
6000 mm	053.3226.600

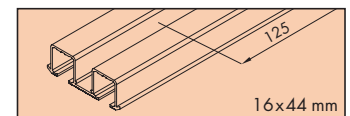

E Doppellaufschiene, Alu eloxiert, gelocht, zum Aufschrauben
Double running track, aluminium anodized, pre-drilled, surface mounted
Rail de roulement double en alu, anodisé, perforé, à visser en applique

2500 mm	053.3231.250
3500 mm	053.3231.350
6000 mm	053.3231.600

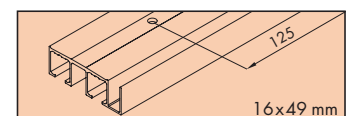

Führungsschiene, Kunststoff anthrazit, 7 mm
Guide track, plastic anthracite, 7 mm
Rail de guidage, en plastique anthracite, 7 mm

2500 mm	053.3012.250
3500 mm	053.3012.350
6000 mm	053.3012.600

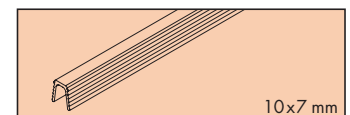

Sonderzubehör / Special accessories / Accessoires spéciaux: 64-66