

Fitting for 1-2 top-running glass doors up to 36 kg (79 lbs.), with screwed on or groove mounted running track. With soft and self closing mechanism. Design Inside.

Product highlights

- Comfort** Quiet, smooth running and soft and self closing system for different door weights
- Productivity** Easy installation with tool-less clip-on system and convenient height adjustment

Technical specifications

- Max. 36 kg (79 lbs.)
- Max. 2000 mm (6'6 3/4")
- Max. 1000 mm (3'3 3/8")
- 6-8 mm (1/4" to 5/16")

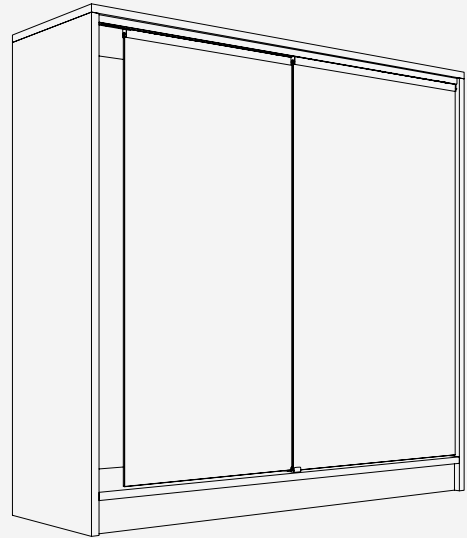

Installation examples



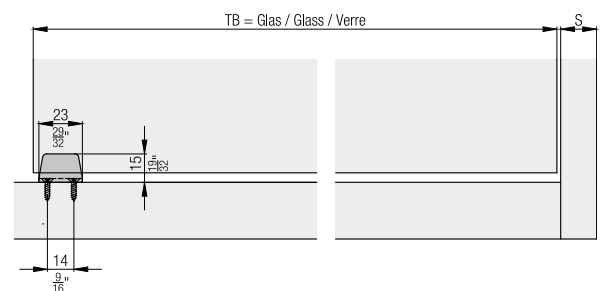
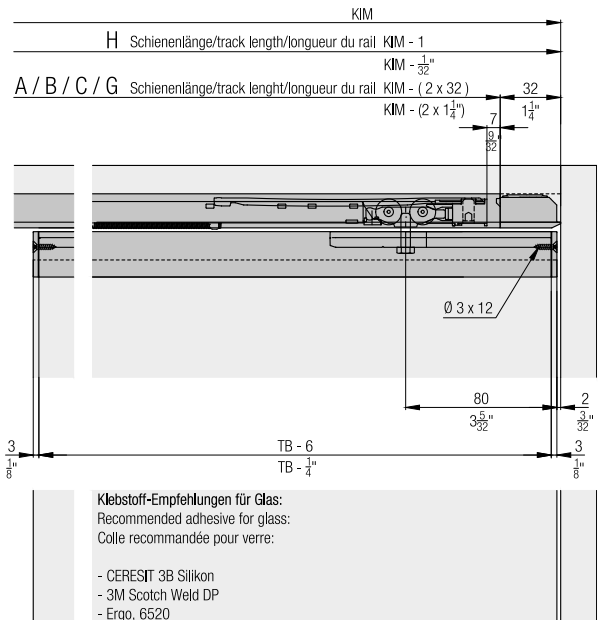
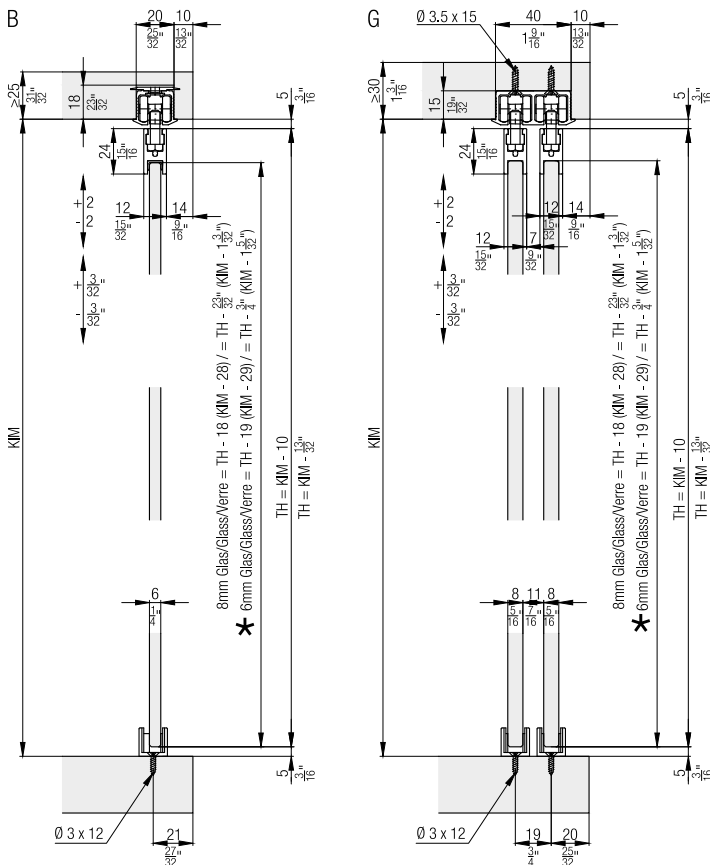



★ Zentrierhilfe für 6mm Glas
Centering help for 6mm glass
Aide de centrage pour verre 6mm

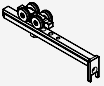

Set for 1 glass door up to 36 kg (79 lbs.), with height adjustment

	No.
Hawa Clipo 36 GPK, for 1 door	053.3361.071

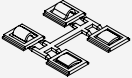
Set consisting of:

		053.3361.071	No.
	Running gear	2	053.3344.071
	Flat countersunk head chipboard screw, 3x12 mm (1/8" x 15/32"), steel, zinc-plated, black	2	600.0000.703
	Stopper, plastic, gray	2	057.3148.071
	Centring help, for 6 mm (1/4") glass	2	053.3139.001
	Bottom guide glass, playfree, chrome-plated, matt	1	053.3097.901
	Slider bottom guide, plastic, grey, 4-piece set	1	053.0146.001
	Flat countersunk head chipboard screw, 3x12 mm (1/8" x 15/32"), steel, zinc-plated	2	766.5030.112

Suspension and glass retaining profiles

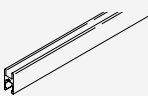
		mm (inch)	No.
	Glass fixing profile, aluminum, anodized	2,500 (8' 2 7/16")	053.3072.250
		3,500 (11' 5 25/32")	053.3072.350
		6,000 (19' 8 7/32")	053.3072.600

Adhesive

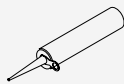
	No.
	Glue Ceresit 3B Silicone, 310 ml
	098.0027.000

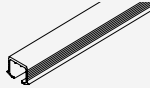
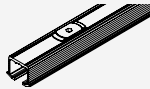
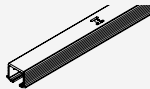
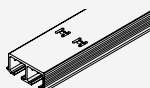
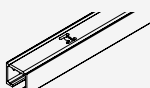

Running tracks

		mm (inch)	No.	
	A: Single running track, for glue fixing, aluminum, anodized	2,500 (8' 2 7/16")	053.3324.250	
		3,500 (11' 5 25/32")	053.3324.350	
		6,000 (19' 8 7/32")	053.3324.600	
	B: Single running track, swivel lug, aluminum, anodized (not for hard wood/ MDF)	2,500 (8' 2 7/16")	053.3327.250	
		3,500 (11' 5 25/32")	053.3327.350	
		6,000 (19' 8 7/32")	053.3327.600	
	C: Single running track, for screw fixing, aluminum, anodized	2,500 (8' 2 7/16")	053.3325.250	
		3,500 (11' 5 25/32")	053.3325.350	
		6,000 (19' 8 7/32")	053.3325.600	
	G: Double running track, for screw fixing, aluminum, anodized	2,500 (8' 2 7/16")	053.3342.250	
		D: Double running track, for screw fixing, aluminum, anodized	3,500 (11' 5 25/32")	053.3342.350
			6,000 (19' 8 7/32")	053.3342.600
	H: Single running track, for screw fixing, aluminum, anodized	2,500 (8' 2 7/16")	053.3326.250	
		3,500 (11' 5 25/32")	053.3326.350	
		6,000 (19' 8 7/32")	053.3326.600	

Track end piece set for single running tracks

	No.
Track-end section, for screw fixing, plastic, gray, 2-piece set	053.3354.071
Track-end section, swivel lug, plastic, gray, 2-piece set	053.3355.051



Set consisting of:

	053.3354.071	053.3355.051	No.
 Track-end piece, for screw fixing, plastic	2		053.0334.001
 Chipboard screw, 4x12 mm (5/32"x15/32"), steel, zinc-plated	2		600.0000.704
 Track-end piece, with swivel lug, plastic		2	053.3351.071

Track end piece set for double running tracks

	No.
Track-end section, double track, swivel lug, plastic, gray, 2-piece set	053.3362.051
Track-end section, double track, plastic, grey, 2-piece set	053.3365.071



Set consisting of:

	053.3362.051	053.3365.071	No.
 Track-end piece, double running track, with swivel lug, plastic	2		053.3352.071
 Track-end piece, Double running track, for screw fixing, plastic		2	053.0335.001
 Chipboard screw, 4x12 mm (5/32"x15/32"), steel, zinc-plated		4	600.0000.704

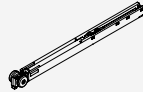

Soft close up to 15/26/36 kg (33/57/79 lbs.)

	No.
Soft close, up to 15 kg (33 lbs.)	057.3159.071
Soft close, up to 26 kg (57 lbs.)	057.3159.072
Soft close, up to 40 kg (88 lbs.)	057.3159.073

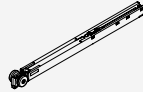
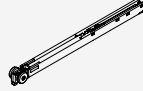
Set consisting of:

	057.3159.071	057.3159.072	057.3159.073	No.
 Soft close, up to 15 kg (33 lbs.)	2			057.3156.071
 Release piece soft close	2	2	2	057.0182.101
 Thread rolling rounded head screw, M2.5x5 mm (3/32"x3/16"), steel, zinc-plated	2	2	2	600.0000.764
 Soft close, up to 26 kg (57 lbs.)		2		057.3156.072
 Soft close, up to 40 kg (88 lbs.)			2	057.3156.073

Handles

	No.
 Handle, for glue fixing, 64 mm (2 17/32"), plastic, chrome-plated, matt, 2-piece set	053.3323.971
 Finger-pull-handle, for glue fixing, 30 mm (1 3/16"), aluminum, anodized, 2-piece set	053.3091.982
	Finger-pull-handle, for glue fixing, 30 mm (1 3/16"), aluminum, anodized, 50-piece set
 Finger-pull-handle, for glue fixing, 40 mm (1 9/16"), aluminum, anodized	053.3158.901

Accessories

	No.
 Track cleaner, plastic, red	040.3142.071

Further installation examples

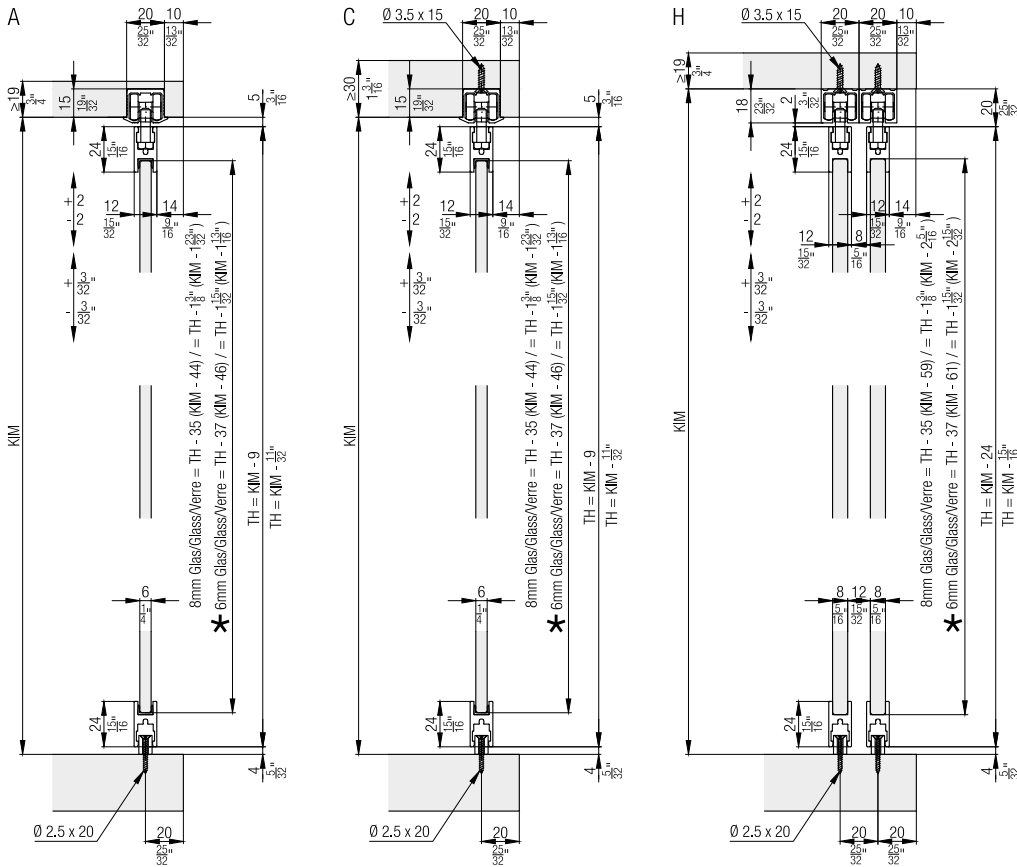

★ Zentrierhilfe für 6mm Glas
 Centering help for 6mm glass
 Aide de centrage pour verre 6mm

Calculations

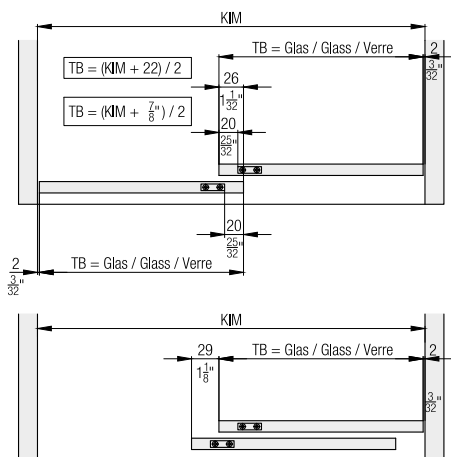

Locking systems

Details from page 242 onwards

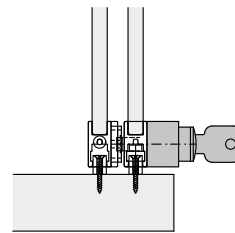

Soft close

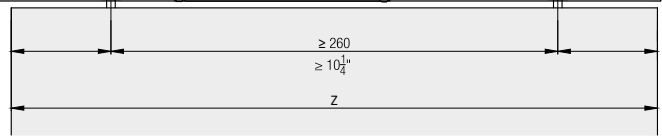
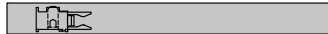

	Z \geq	
	1	2
Hawa Porta 40 H	1' 4 $\frac{17}{32}$ ''	2' 0 $\frac{13}{32}$ ''
Hawa Porta 40 GE	1' 2 $\frac{11}{16}$ ''	1' 10 $\frac{11}{16}$ ''
Hawa Clipo 26 H IS	1' 4 $\frac{17}{32}$ ''	2' 0 $\frac{13}{32}$ ''
Hawa Clipo 26 H MS	1' 6 $\frac{1}{32}$ ''	2' 1 $\frac{29}{32}$ ''
Hawa Clipo 36 H IS	1' 4 $\frac{17}{32}$ ''	2' 0 $\frac{13}{32}$ ''
Hawa Clipo 36 H MS	1' 6 $\frac{1}{32}$ ''	2' 1 $\frac{29}{32}$ ''
Hawa Clipo 36 HM IS	1' 4 $\frac{17}{32}$ ''	2' 0 $\frac{13}{32}$ ''
Hawa Clipo 26 GR IS	1' 4 $\frac{17}{32}$ ''	2' 0 $\frac{13}{32}$ ''
Hawa Clipo 36 G IS	1' 4 $\frac{17}{32}$ ''	2' 0 $\frac{13}{32}$ ''
Hawa Clipo 36 GPK IS	1' 4 $\frac{17}{32}$ ''	2' 0 $\frac{13}{32}$ ''
Hawa Clipo 36 GPPK IS	1' 4 $\frac{17}{32}$ ''	2' 0 $\frac{13}{32}$ ''
Hawa Regal C 26 HM IS	1' 4 $\frac{17}{32}$ ''	2' 0 $\frac{13}{32}$ ''
Hawa Regal C 26 GR IS	1' 3 $\frac{9}{4}$ ''	1' 11 $\frac{5}{8}$ ''

	Z \geq	
	1	2
Hawa Porta 40 H	420	620
Hawa Porta 40 GE	376	576
Hawa Clipo 26 H IS	420	620
Hawa Clipo 26 H MS	458	658
Hawa Clipo 36 H IS	420	620
Hawa Clipo 36 H MS	458	658
Hawa Clipo 36 HM IS	420	620
Hawa Clipo 26 GR IS	420	620
Hawa Clipo 36 G IS	420	620
Hawa Clipo 36 GPK IS	420	620
Hawa Clipo 36 GPPK IS	420	620
Hawa Regal C 26 HM IS	420	620
Hawa Regal C 26 GR IS	400	600

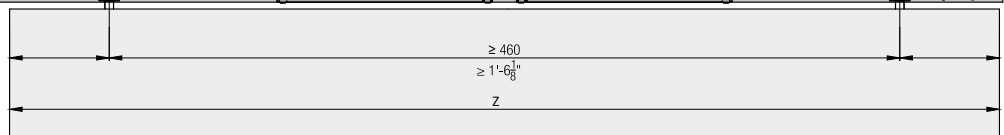

Accessories

- Locking systems from page 242
- Glass recommendations from page 249

Planning/execution

Further information about the product can be found on www.hawa.com.